

Model X6 Mobile LED Display

# Specifications

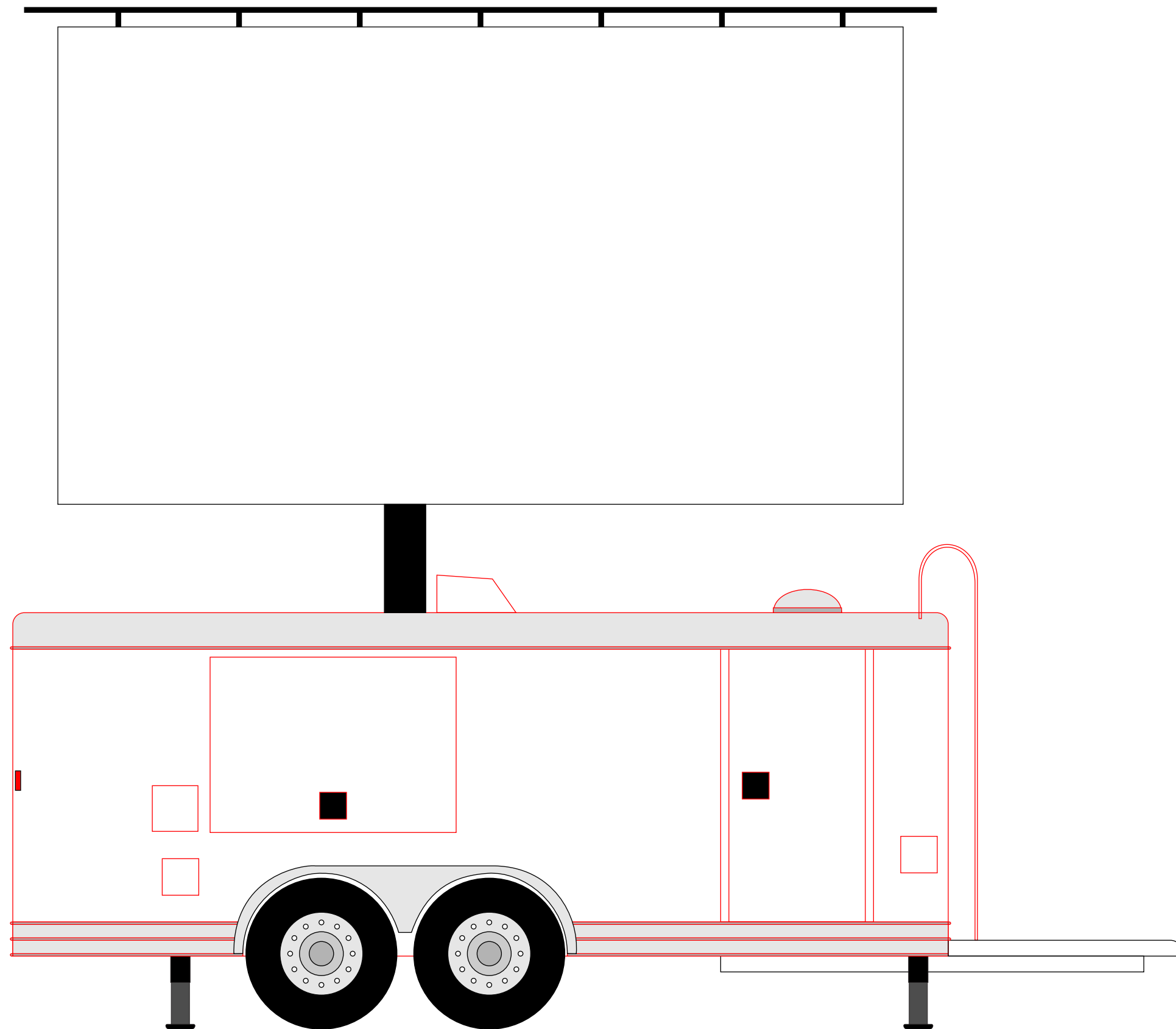

[www.FDGtv.com](http://www.FDGtv.com)  
[www.IntenseSystems.com](http://www.IntenseSystems.com)



[www.FDGtv.com](http://www.FDGtv.com)

# Model X6 Mobile LED Display



[www.FDGtv.com](http://www.FDGtv.com)  
[www.IntenseSystems.com](http://www.IntenseSystems.com)

A versatile mobile LED display

Events  
Advertising  
Indoor  
Outdoor  
Rain or Shine

Setup in as little as 30 minutes

High resolution display

16:9 aspect ratio

Rotatable screen 360 degrees

Self contained no external power needed. Diesel generator provides approximately 24 hours of continuous operation

Multipal video input capable

SDI  
HDSDI  
3GSDI  
DVI  
HDMI  
VGA  
Composit

# Specifications



## Trailer

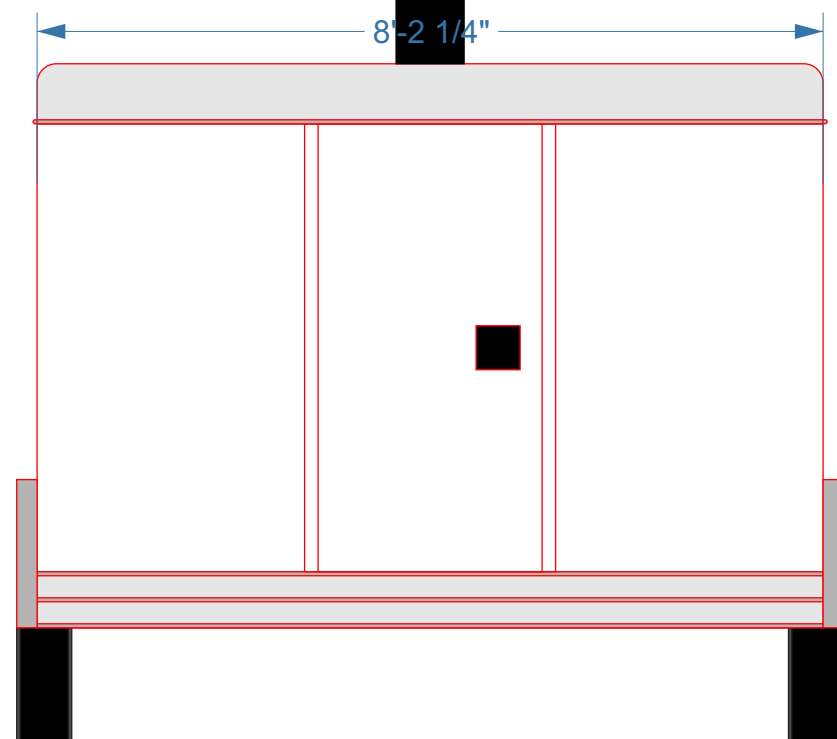
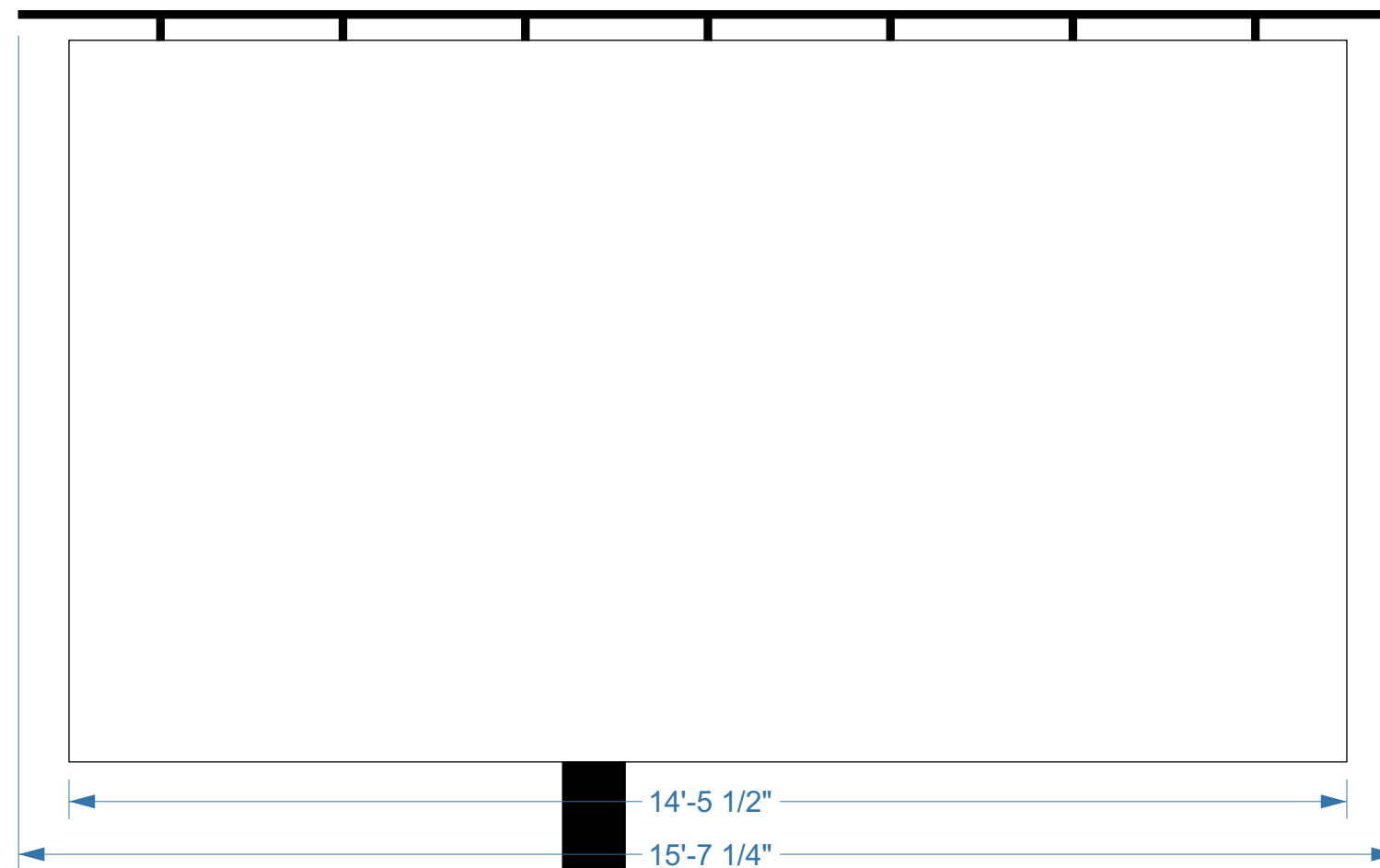
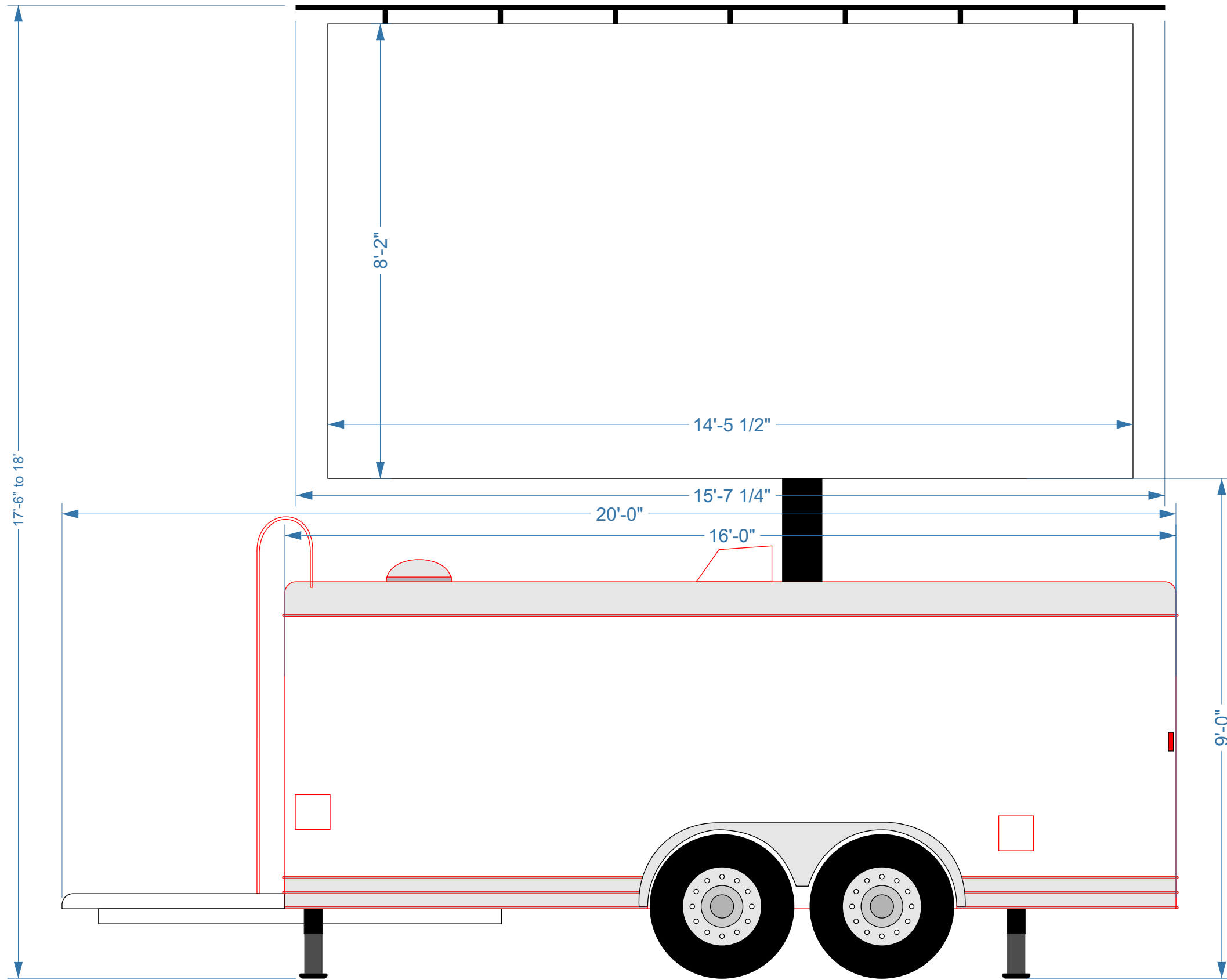

# Specifications



## Trailer Top View

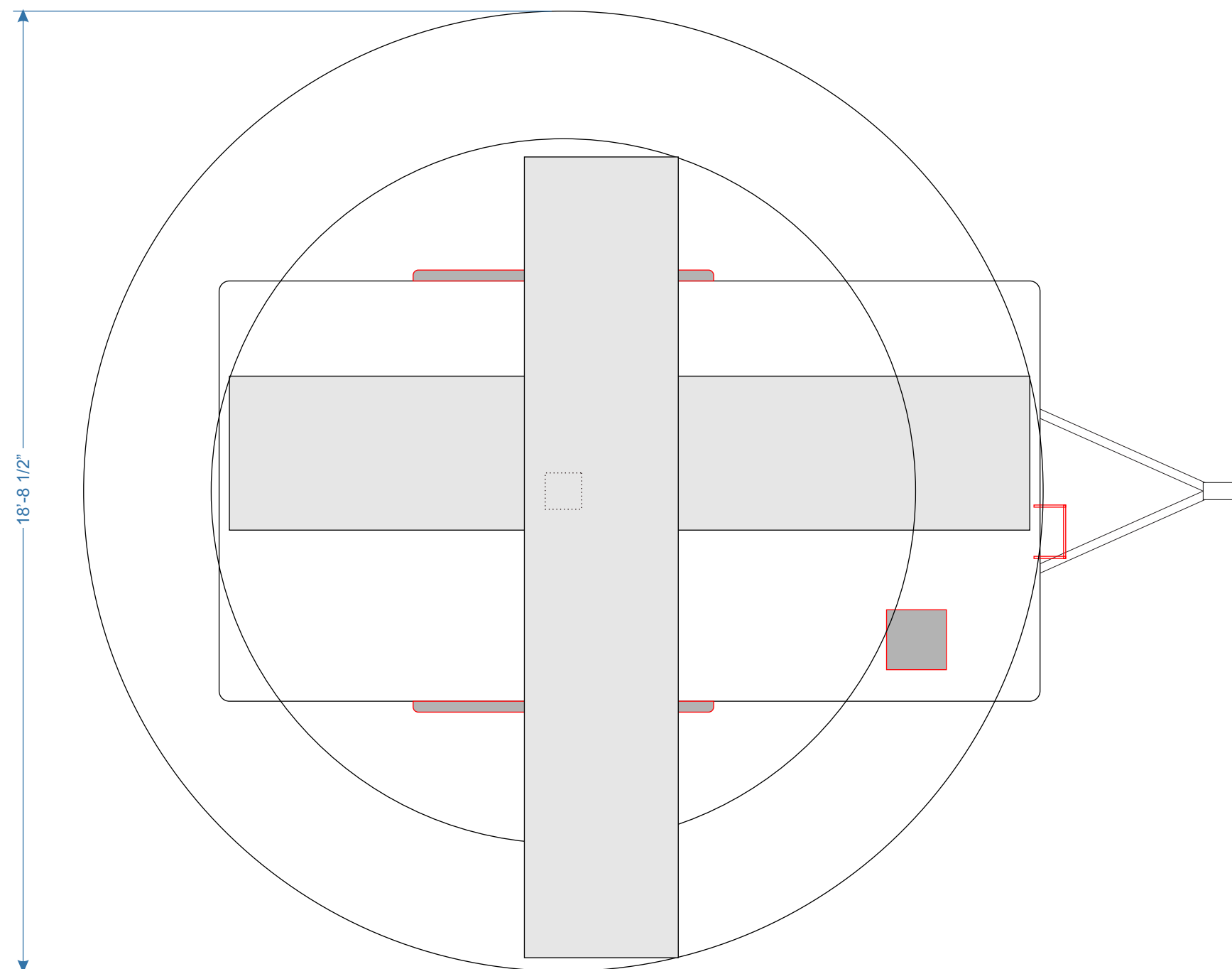

Total Weight	8,500 lbs
Tongue Weight	800 lbs
Transport Ground Contact	25.3 psi at tire to ground contact
Dimensions (WxDxH)	8' x 20' x 7'
Brake System	Electric Braking System
Axle	2 axles
Wheels	4 wheels, 235-85R16
Lift	Hydraulic pump to raise and lower mast
Display Rotation	360 degrees of rotation, in 15 degree increments
Wind Load	40 mph max wind load when screen is deployed
Level	4 stabilizers to level trailer and give load support
Ball Coupler	2 5/16"

## Generator

Type	Kohler 20kW
Fuel Tank	50 Gallon tank
Power	3 phase, 208VAC
Noise Level	Insulated compartment for noise reduction

# Specifications



## Displays

Dimensions (W x H)	14'-5 1/2" x 8'-2"
Extended Height Size	18'
Aspect Ratio	16:9.04
Brightness	8,000 NITS
Pitch	6.00 mm
Video Input Resolution	1920 x 1080
Resolution	734 x 414 Pixels
IP Rating	65
Video Signal Inputs Types	SDI
	HD SDI
	3G SDI
	HDMI
	DVI
	VGA
	Composit